

BEFESTIGUNGSSYSTEM FÜR BITUMENDÄCHER

Montageset

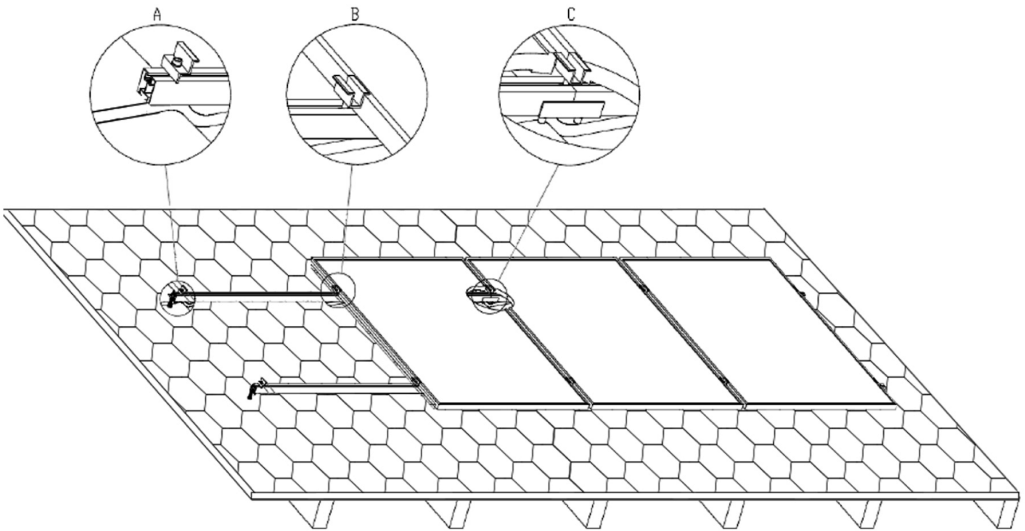

TECHNISCHE ZEICHNUNGEN

Die tatsächlichen Abmessungen der Bauteile können geringfügig von den Angaben in diesem Datenblatt abweichen.

SCHEMATISCHER AUFBAU DES MONTAGESETS - FÜR BITUMENDÄCHER

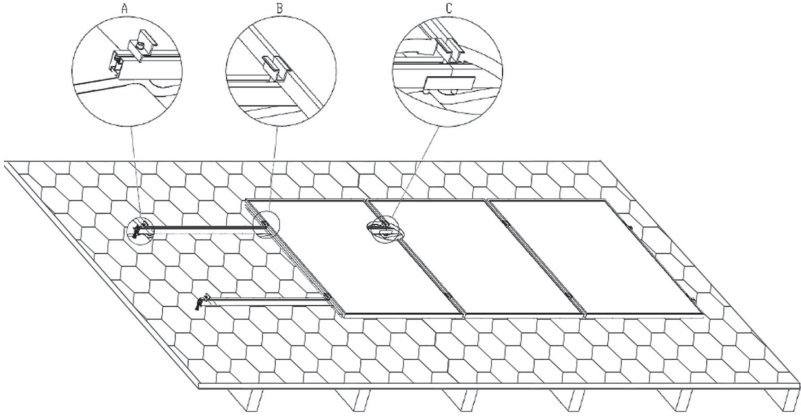

Einzelheiten A

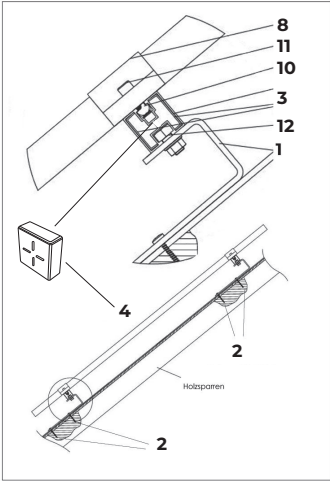



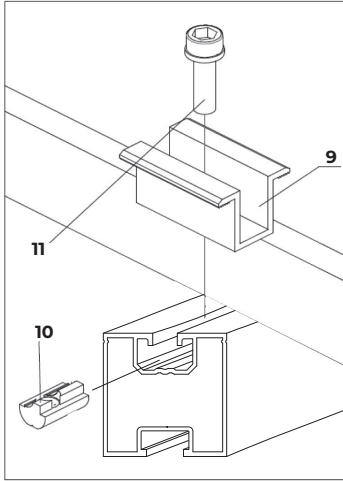



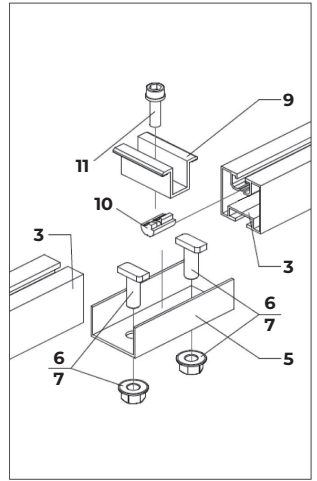



Einzelheiten B

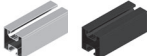
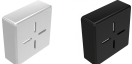

Einzelheiten C



KOMPONENTEN DES MONTAGESETS - FÜR BITUMENDÄCHER

Pos.	Artikel	Anzahl im Basisset	Anzahl je Erweiterungsset	
1	Befestigungshaken für Bitumendächer Artikelnr. 90584010	4	4	
2	Tellerkopf-Holzbauschraube 8x80mm Artikelnr. 36296080	8	8	
3	Montageschiene P2 40x40 1,2m Artikelnr. 9589212 (silber) / Artikelnr. 9589312 (schwarz)	2	2	
4	Abdeckkappe für Montageschiene Artikelnr. 90589015 (silber) / Artikelnr. 90589016 (schwarz)	4	0	
5	Längsverbinder für Montageschienen Artikelnr. 90589110	0	2	
6	Hammerkopfschraube Artikelnr. 90589121	4	8	
7	Bundmutter mit Sperrverzahnung Artikelnr. 90589130	4	8	
8	Endklemme für Solarmodule 30mm Artikelnr. 90589140 (silber) / Artikelnr. 90589141 (schwarz)	4	0	
9	Mittelklemme für Solarmodule Artikelnr. 90589150 (silber) / Artikelnr. 90589151 (schwarz)	0	2	
10	Nutenstein mit Federkugel Artikelnr. 90589160	4	2	
11	Zylinderkopfschraube Artikelnr. 90589170	4	2	
12	Federring Artikelnr. 90589180	4	2	

Befestigungshaken für Bitumendächer

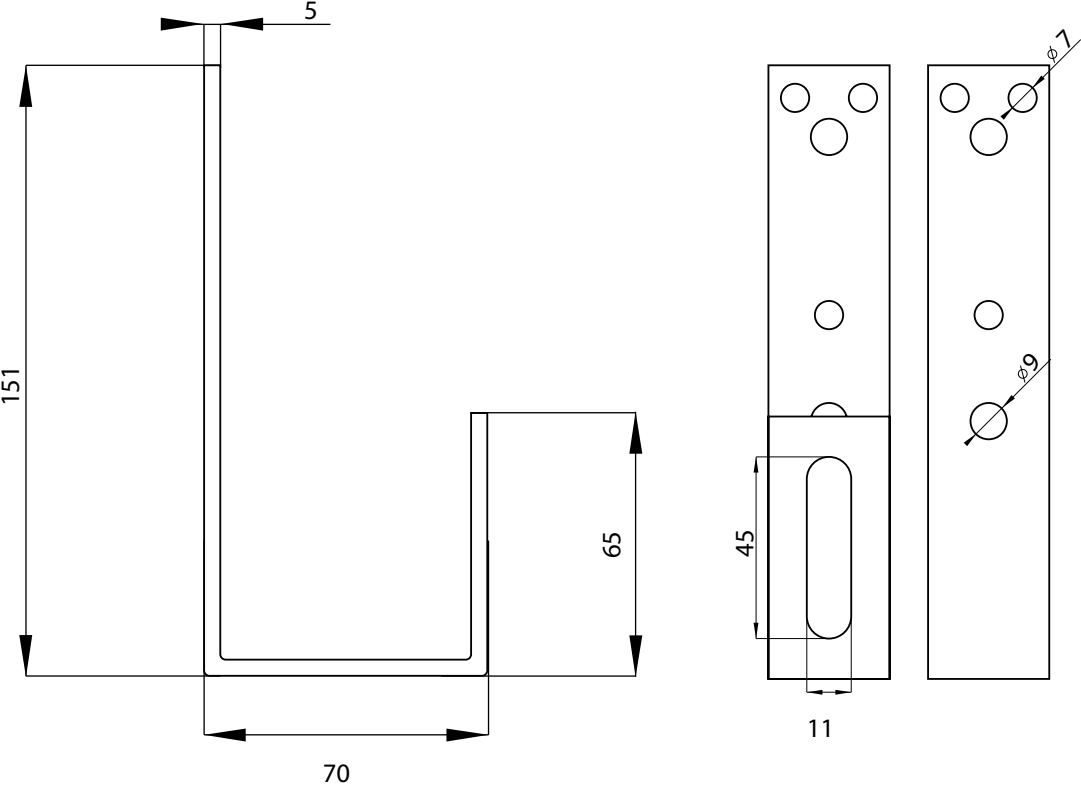

Tellerkopf-Holzbauschraube 8x80mm

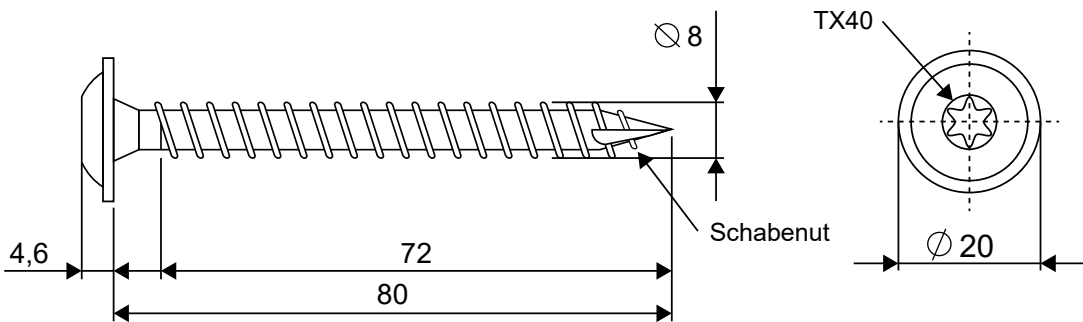

Montageschiene P2 40x40

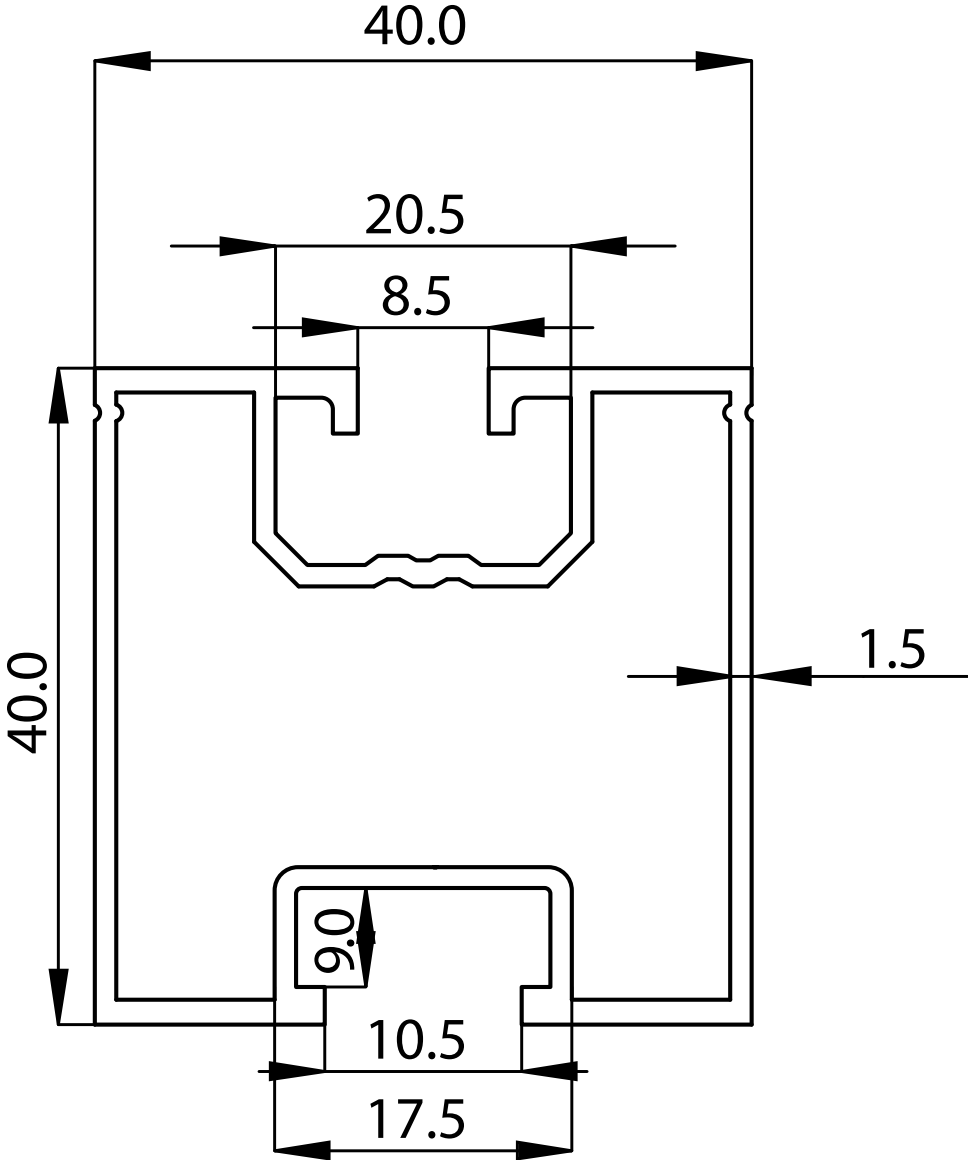

Abdeckkappe für Montageschiene

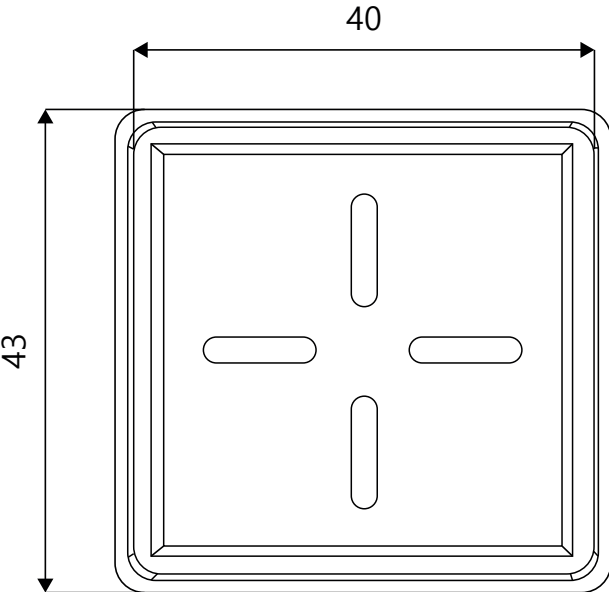

Längsverbinder für Montageschienen

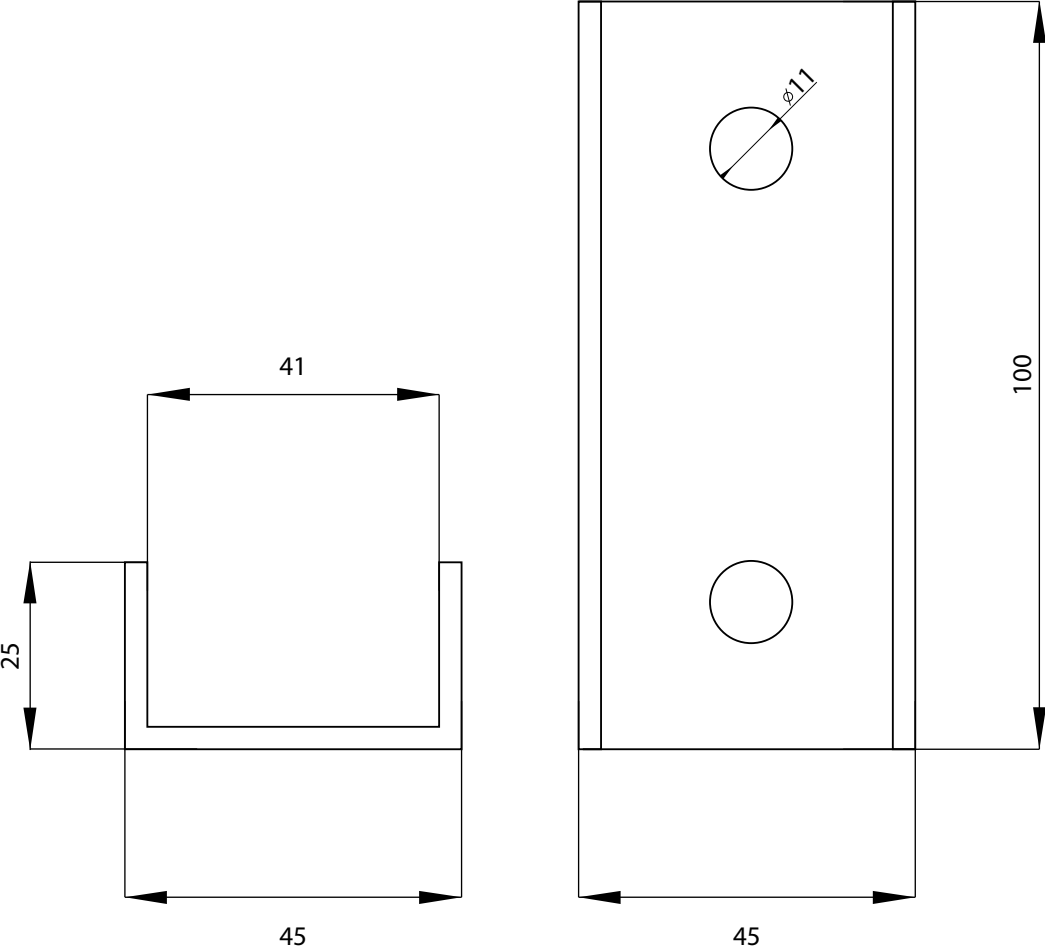

Hammerkopfschraube M10 x 32,5mm für Montageschiene P2

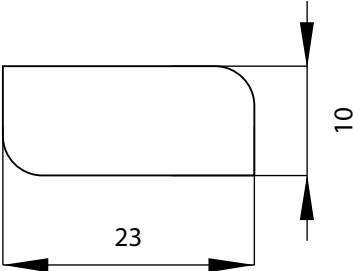
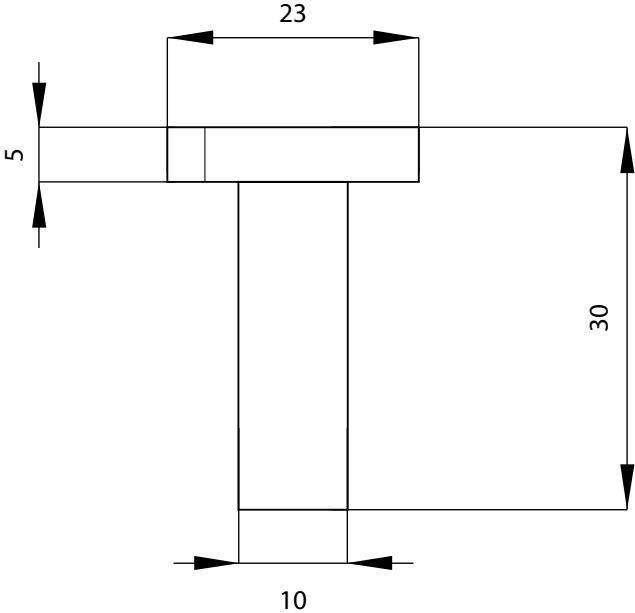

Bundmutter mit Sperrverzahnung

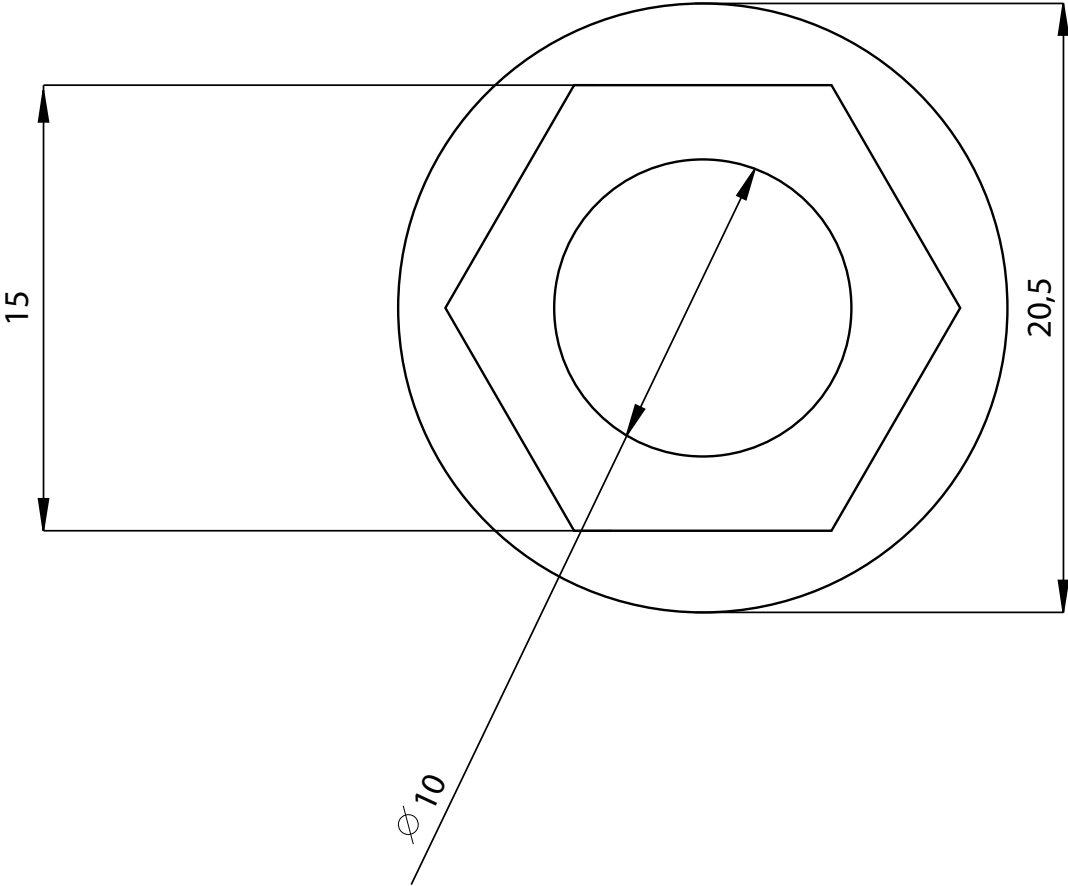

Endklemme 30mm für Solarmodule

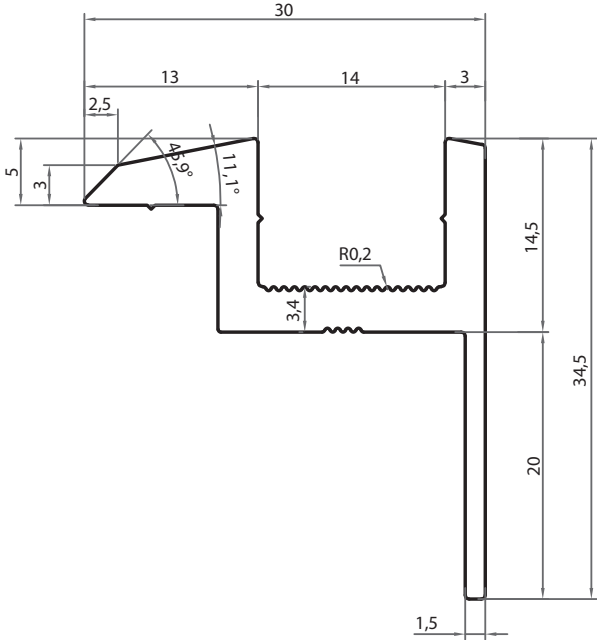
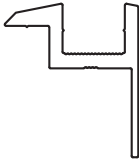
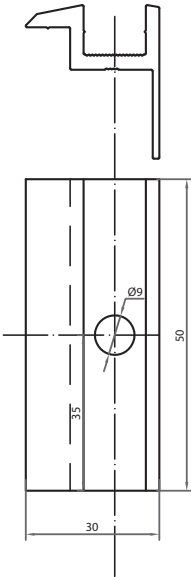

Mittelklemme für Solarmodule

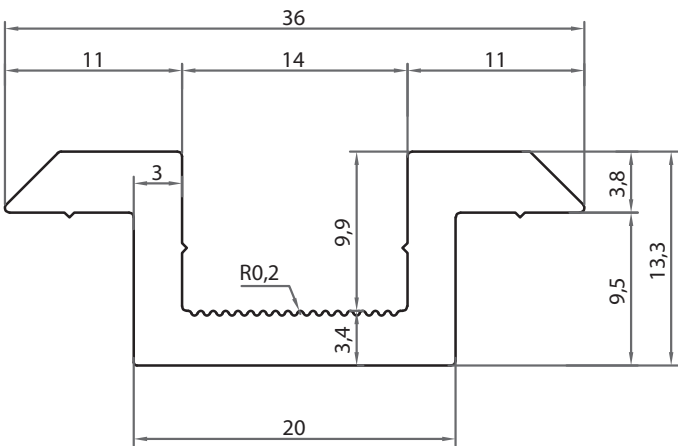
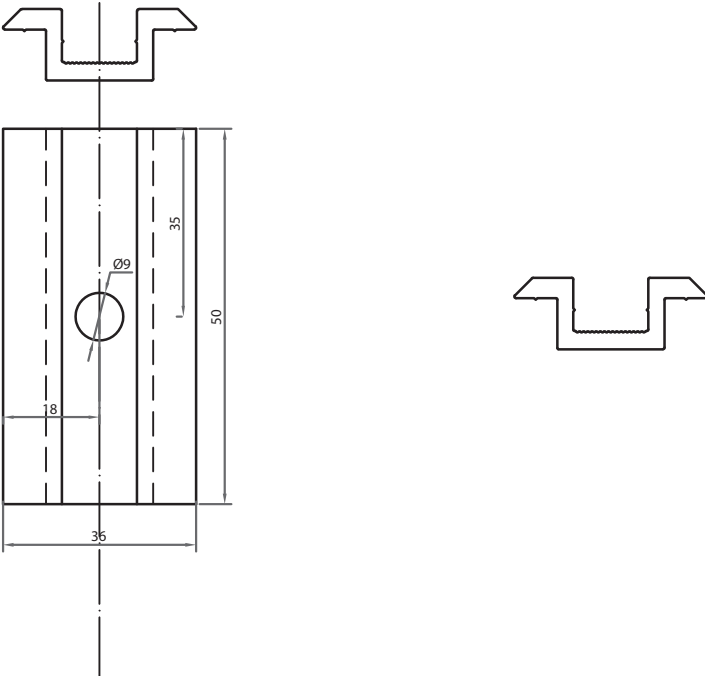

Nutenstein mit Federkugel

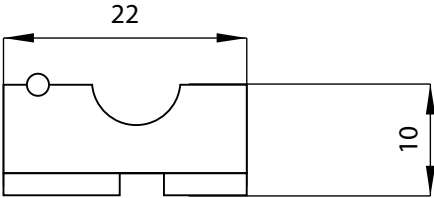
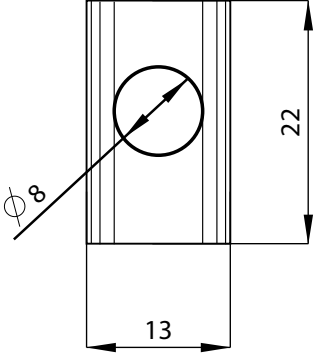
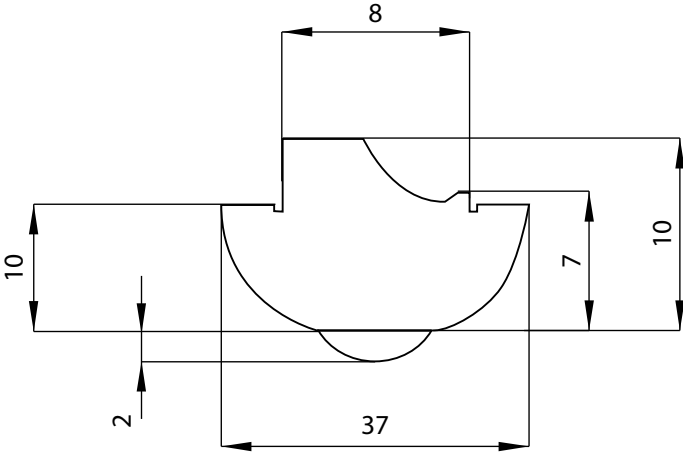

Zylinderkopfschraube

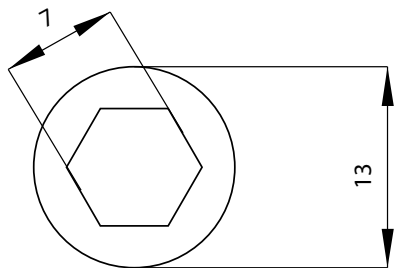
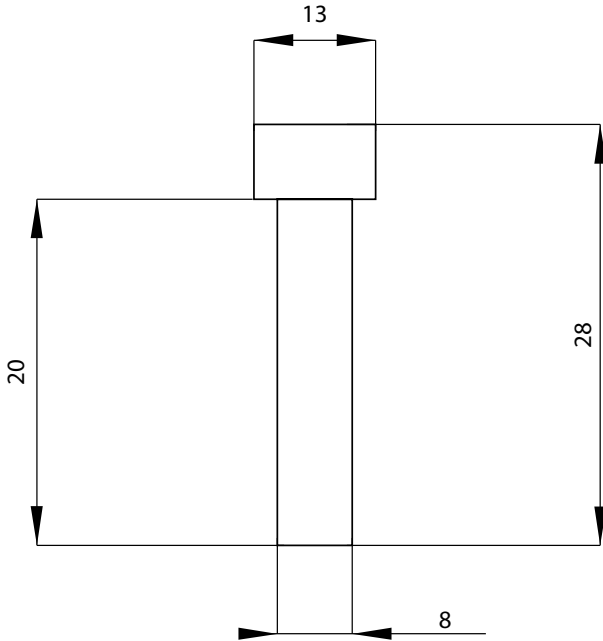

Federring

